

# FLUSH LOCKSETS

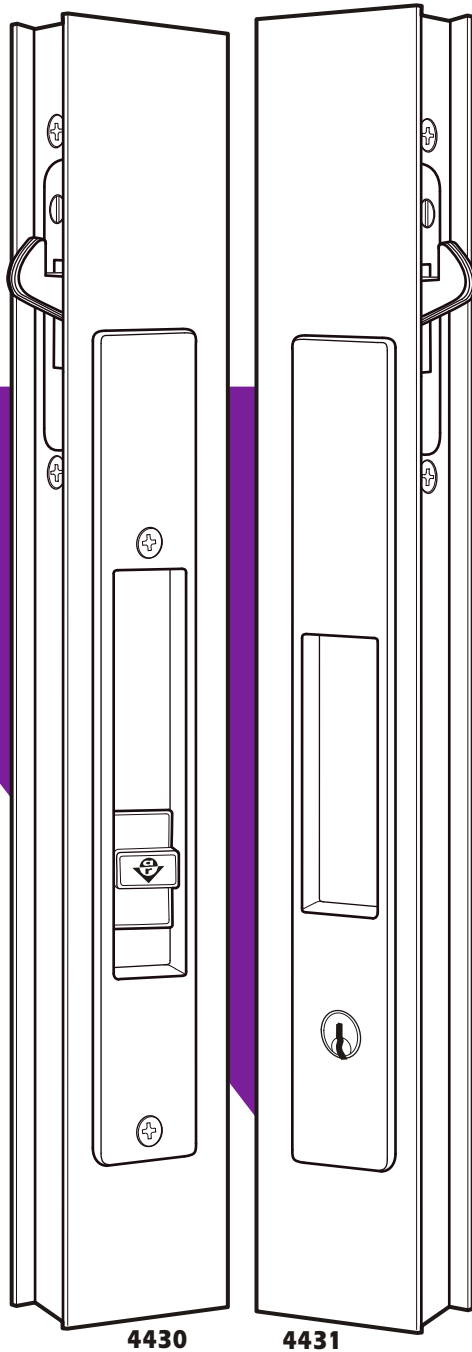

## Flush Locksets

Including Deadlock

### 4430, 4431

ANSI/BHMA Type E8292 (Grade 2)

#### ▼ Backset

Variable.  
Minimum: .625 in.  
Maximum: 1.28 in.  
(from face of lock to  
escutcheon and  
cylinder centerline).

#### ▼ Escutcheons

Molded ABS resin  
plastic. Black Satin  
finish. (Custom  
colors available to  
volume users).  
Deeply recessed  
finger pull on both  
sides. Fits same  
cutout as metal  
4189/4190 locksets.

#### ▼ Function

Similar in function and nearly identical in size to the all-metal 4189 and 4190 Flush Locksets, these economical units feature escutcheons molded of sturdy ABS resin. The Black Satin finish of the 4430 and 4431 lends to aluminum door stiles an elegance beyond their low cost.

#### ▼ Anti-Lift Lock Mechanism

Basic MS1848-09 (radius ends) or MS1848-10 (square ends) is supplied. Bolt is self-protecting, adjustable for reach.

#### ▼ Inside Operation

Vertical slide button projects or retracts deadlock bolt.

#### ▼ Outside Operation (4431 Only)

Key in five-pin Schlage "C" Keyway cylinder projects or retracts bolt. Other cylinder makes not available.

#### ▼ Stile Thickness

May be 1" to 1-3/8". Available on special order for stiles 1-3/8" thick or greater at extra cost.

#### ▼ Stile Depth

Minimum clear depth: Backset plus 9/16".

#### ▼ Operation

Both locksets operated from inside by a simple up or down movement of a slide button, set flush in the deeply recessed finger pull. The lock mechanism (latching action unavailable) is the time-tested and field-proven Adams Rite MS1848 and features the adjustable, self-protecting bolt. Matching "dummy set" also available (4432).



# 4430, 4431 Flush Locksets

## DIMENSIONS

**INCHES**  
MILLIMETERS  
Nominal, subject to tolerance extremes.

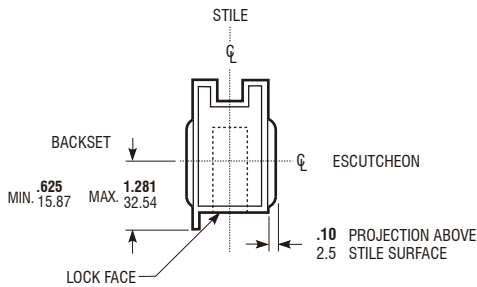
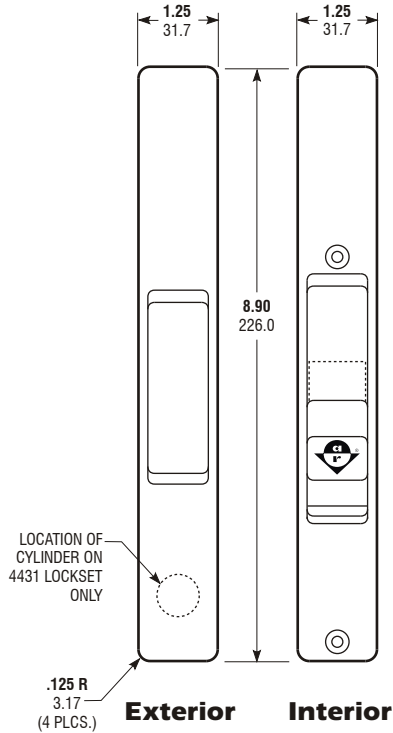

**Escutcheons**

## INSTALLATION

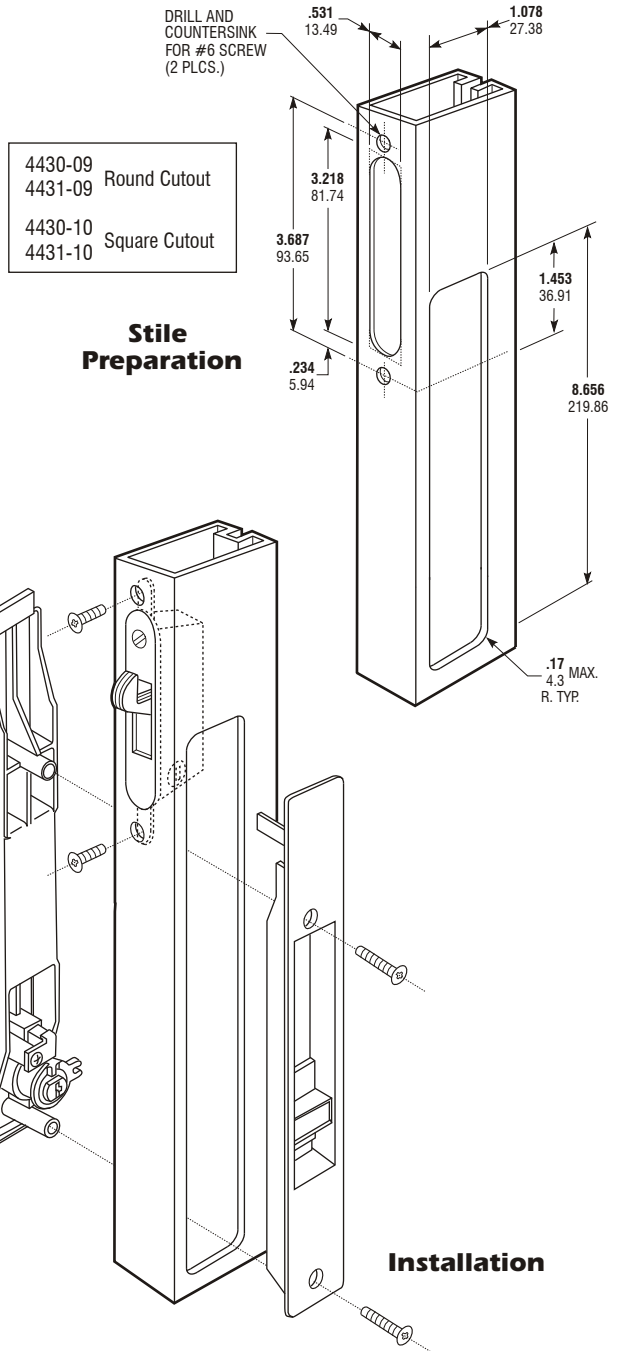

## HOW TO ORDER

Specify quantity and the following information.  
Order related hardware separately.

<b>Lockset Exterior</b>	<b>Lock Face</b>	<b>Stile Thickness</b>
<b>4430</b> w/o Cylinder	<b>09</b> Radius	<b>00</b> 1" - 1-5/16"
<b>4431</b> w/Cylinder	<b>10</b> Square	<b>05</b> 1-3/8" - 1-5/8"
		<b>08</b> 1-3/4" - 2"

**4431 - 09 - 05**

## OPTIONS

Specify 4431 if outside key-cylinder operation required; 4430 if not. Add Dash -10 for square-ended lock face or -09 for round end. Dummy set 4432 available. Accessory Grip Pull 4453 for inside also available.

## STANDARD PACKAGE

4431, with cylinder, and 4430, without cylinder, are each complete packages. Shipped individually boxed with mounting screws. 4431 includes two keys. Weight: 1-1/4 lbs. Standard 4431 units are keyed different (KD). Contact factory for special keying.